

Quantum measurements with an amplitude-squeezed-light beam splitter

Junxiang Zhang, Tiancai Zhang, Ruifang Dong, Jing Zhang, Changde Xie, and Kunchi Peng

Quantum measurement of amplitude fluctuation is performed by the injection of 2.5-dB amplitude-squeezed light produced by a quantum-well laser into the dark port of a beam splitter as the meter wave. It is shown that the measurements satisfy the criteria of quantum nondemolition measurement. The measured transfer coefficient and the quantum-state preparation ability are 1.07 and 0.8, respectively.

© 2001 Optical Society of America

OCIS codes: 270.6570, 270.2500, 140.2020.

Quantum nondemolition (QND) measurement proposed first by Braginsky¹ is an approach for nondestructive measurement of observable quantum; that is, it allows one to measure observable quantum without disturbing it. The strategies are to indirectly measure the meter wave, which is coupled to a signal wave through some specially designated interaction, and then to deduce the desired information on the observable signal wave from the measurement without disturbing the signal wave. A number of experimental attempts of implementing QND measurements were performed when a signal beam was coupled to a meter beam via an optically nonlinear medium.²⁻⁴ Other coupling methods such as optoelectrical and electromechanical coupling were also applied to perform the QND measurement.⁵⁻⁷ Recently the long-standing challenge for repeated QND measurements of a continuous variable was successfully mastered^{8,9} with a monolithic dual-port degenerate optical parametric amplifier.

It is well known that a beam splitter is the simplest and most popular optical device in optical systems. Early it has been demonstrated theoretically that a beam splitter with a squeezed-light input can be used to implement the QND measure-

ment.^{10,11} Two such QND experiments have recently been performed in which the beam splitter was used to couple a signal wave to a nonclassical meter wave that was a squeezed vacuum wave¹² or a twin beam of intensity quantum correlation.¹³ Because a squeezed vacuum wave or a twin beam is generated from an optical parametric process, the optical systems in these experiments are quite complex. The amplitude-squeezed light generated from a pump-noise-suppressed laser diode (LD) can be obtained from a compact device with intermediate optical power, large squeezing bandwidth, and rich wavelength. With some line-narrowing techniques such as injection-locking or external optical feedback,¹⁴⁻¹⁶ the amplitude squeezing of a LD has been improved to 3 dB. Several experiments of applying amplitude-squeezed light from a LD to improve the sensitivities of spectroscopic measurement have been completed.¹⁷⁻¹⁹ But so far, the amplitude-squeezed light from a LD has not been used in a quantum measurement that meets QND criteria. In this paper we present the realization of a back-action-evasion measurement of the amplitude component of the signal by coupling it with the amplitude-squeezed meter wave generated from a LD on a beam splitter that acts as a QND coupler. The measured results fulfill the criteria of QND detection in the quantum region.

First, we simply present the operation principle of the device. Assume that a beam splitter of power transmission T and reflectivity $R = 1 - T$ couples the detected signal wave to the meter wave. The relation between the input (X_s^{in} for the signal wave and X_m^{in} for the meter wave) and the output (X_s^{out} for the

The authors are with the Institute of Opto-Electronics, Shanxi University, The Key Laboratory of Quantum Optics, Ministry of Education, China, Taiyuan 030006, China. Junxiang Zhang's e-mail address is zjx1966@yahoo.com.cn. K. Peng's e-mail address is kcpeng@sxu.edu.cn.

Received 14 February 2001.

0003-6935/01/325949-05\$15.00/0

© 2001 Optical Society of America

signal wave and X_m^{out} for the meter wave) quadrature amplitudes at the beam splitter is expressed as¹²

$$\begin{pmatrix} X_s^{\text{out}} \\ X_m^{\text{out}} \end{pmatrix} = \begin{bmatrix} -\sqrt{R} & \sqrt{T} \\ \sqrt{T} & \sqrt{R} \end{bmatrix} \begin{pmatrix} X_s^{\text{in}} \\ X_m^{\text{in}} \end{pmatrix}. \quad (1)$$

According to the same procedure used in Ref. 13, we can easily deduce the transfer coefficient ($T = T_s + T_m$) and the normalized condition variance of the device ($V_{s/m}$) from their original definition,^{20,21}

$$T = T_s + T_m = (\text{SNR}_s^{\text{out}} + \text{SNR}_m^{\text{out}}) / \text{SNR}_s^{\text{in}}, \quad (2)$$

$$V_{s/m} = V_s^{\text{out}} [1 - C^2(\delta X_s^{\text{out}} \delta X_m^{\text{out}})], \quad (3)$$

where T_s and T_m are the transfer coefficients of signal and meter waves, respectively, the signal-to-noise ratio (SNR) is defined as the ratio of the intensity of a small modulation at a given frequency (21 MHz for our scheme) for the quadrature amplitude X by the quadrature amplitude noise power at the same frequency

$$\text{SNR} = \left| \frac{\langle X(\omega) \rangle^2}{V_X(\omega)} \right|.$$

$V_{S(M)}^{\text{in(out)}}$ is the fluctuation variable of the input (output) signal wave or the input (output) meter wave, and $C^2(\delta X_s^{\text{out}} \delta X_m^{\text{out}})$ is the normalized correlation function between the output signal and meter waves.

Both the transfer coefficient and the conditional variance are used for quantifying the properties of a QND device. T characterizes the quality of the QND device as an quantum optical tap. The quantum-state preparation ability of the QND device can be conveniently evaluated by the conditional variance ($V_{s/m}$). If the input signal and meter beams are shot-noise limited, then the standard quantum limits $T_s + T_m \leq 1$ and $V_{s/m} \geq 1$ are created. When with the squeezed meter input we have $2 \geq T_s + T_m > 1$, the device operates as the quantum optical tap,²¹ and meanwhile $V_{s/m} < 1$ means the readout from the output meter wave gives some exact information about the outgoing signal wave.²¹

We can calculate from Eqs. (2) and (3) the transfer coefficient and conditional variance,

$$T = \frac{R}{R + TV_m^{\text{in}} + (1 - \eta)/\eta} + \frac{T}{T + RV_m^{\text{in}} + (1 - \eta)/\eta}, \quad (4)$$

$$V_{s/m} = \frac{(1 - \eta) + \eta V_m^{\text{in}}}{(T + RV_m^{\text{in}})\eta + (1 - \eta)}, \quad (5)$$

where V_m^{in} is the normalized quadrature amplitude fluctuation variable of the input meter wave and η is the detection efficiency. In Eqs. (4) and (5) we have assumed that the input signal wave is a coherent state, i.e., $V_s^{\text{in}} = 1$. It is obvious that for the amplitude-squeezed input meter wave $V_m^{\text{in}} < 1$ and

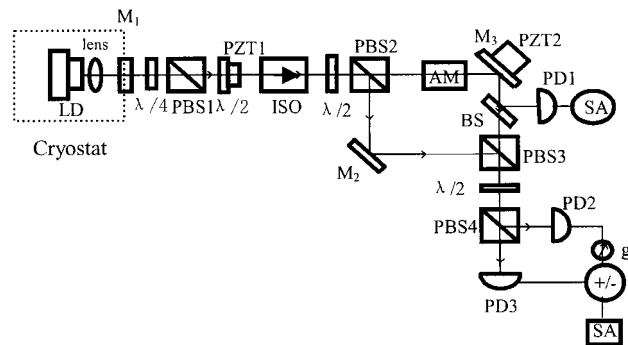

Fig. 1. Experimental setup. The laser diode (LD) and collimating lens are cooled in a cryostat. M_1 , antireflected mirror; M_2 and M_3 , high-reflection mirrors; PBS, polarized beam splitter; PZT, piezoelectric translator; ISO, optical isolator; AM, amplitude modulator; BS, beam splitter with $R = 46\%$; PD1, PD2, and PD3, photodiodes with 90% quantum efficiency; SA, spectrum analyzer.

perfect detection ($\eta = 1$), the quantum measurement fulfilling the QND criteria ($T > 1$, $V_{s/m} < 1$) can be matched.²⁰ When we substitute $V_m^{\text{in}} = 0.56$ (corresponding to the amplitude squeezing of 2.5 dB) and $\eta = 0.9$ into Eqs. (4) and (5), the improved measurements $T = 1.12$ and $V_{s/m} = 0.75$ should be obtained with a 50% beam splitter in this scheme.

The experimental setup is shown in Fig. 1. Both the LD (Spectra Diode Laboratories SDL-5411G1) and collimating lens were cooled down to 77 K inside a liquid nitrogen cryostat to increase emitting efficiency. At the low temperature the threshold current, the emission wavelength, and the overall detection efficiency of the LD were 2.5 mA, 815 nm, and greater than 50%, respectively. The amplitude-squeezed light was generated from the cooled LD with weak optical feedback. Owing to the effect of birefringence on the laser and collimating lens at the low temperature, it is difficult to obtain large squeezing of amplitude noise at a given polarization direction.¹⁵ The phenomenon can be explained by the anticorrelation of the photon-number fluctuation between orthogonally polarized fields.¹⁴ In the total output, including two orthogonal polarizations, the fluctuation of the photon number was partially eliminated owing to the anticorrelation, but for the light polarized at a certain direction, the fluctuation increased owing to the absence of the anticorrelation. Usually in experimental systems the polarizer has to be applied. So to keep the anticorrelation, we added a $\lambda/4$ wave plate at the exit of the cryostat to compensate for the birefringence to restore the linear polarization of the output field of the LD, and at the same time all anticorrelation components were retained. Then the inserted polarizers or wave plates will not influence the anticorrelation in the light beam, so the squeezing will not be reduced. Our experiment demonstrated that the above-mentioned simple method was effective and that an amplitude squeezing of 2.2 dB was measured, which was much better than that without the $\lambda/4$ wave plate (1.2 dB). The polarizer PBS1 was used to purify further the

linear polarization light, and the first $\lambda/2$ wave plate was employed to align to the polarization direction of the optical isolator (ISO). To decrease the optical losses, which are quite harmful for squeezing, both sides of the $\lambda/2$ wave plate were coated with antireflection films, and the $\lambda/2$ plate also served as the weak feedback element in suppressing the amplitude noise of the laser. Because the light beams that are reflected from the front and back surfaces of the $\lambda/2$ wave plate are in phase, there is no unexpected effect on the squeezing of the different phase feedback lights from the two surfaces. The feedback was carefully aligned with the PZT stuck on the $\lambda/2$ wave plate to get the maximum squeezing. The second $\lambda/2$ wave plate behind the ISO orientated the polarization direction of light relative to the second polarizer PBS2, which separated the input power into two parts: (1) A small portion ($\sim 4\%$) transmitted was used as the signal wave, the noise of which was increased to the noise level of a coherent state owing to the large reflective loss, and (2) the large portion reflected was employed as the meter wave required by the quantum measurement that kept almost all squeezing of amplitude fluctuation and input power. The main part of the system is the QND coupler—a 50% beam splitter that consists of an input polarizer (PBS3), a half-wave plate, and an output polarizer (PBS4). The signal and meter input beams have orthogonal polarization, so that the input polarizer superimposes two beams along the input direction of the coupler, the half-wave plate rotates these polarizations by 45° , and the second polarizer (PBS4) acts as the 50% beam splitter. The evaluation of the characterization of the QND devices requires the measurement of the correlation $C^2(\delta X_s^{\text{out}} \delta X_m^{\text{out}})$ between the output signal and meter waves and measurement of the transfer coefficients. To this end, three large-area detector photodiodes (PD)1 (EG&G FND100), PD2, and PD3 (EG&G C30809E) are used, and the alternating current (ac) is amplified by the amplifiers (Optical Electronics, Inc. AH0013 and MITEQ, Inc. AU-1310-BNC, and the unit gain bandwidth is 100 MHz) and fed into the spectrum analyzer to detect the noise power. The spatial mode matching that was $\sim 97\%$ between the input signal and the meter waves at PBS4 was observed by the interference contrast. The phase difference between the input signal and the meter waves was controlled by a servo loop driving the PZT2 to maximize the power of one of the two output waves from PBS4 (the other one has minimum effect); in this case, the input signal and the meter waves are in phase.

To measure the noise power spectrum of the input meter wave, we blocked the input signal wave and detected the noise power of the input meter wave with PD2 and PD3. Figure 2 shows the measured noise power spectral density with the LD biased at 34.58 mA, which produces a photon current of 9.06 mA at each detector. Curve a is given by the noise spectrum of a photocurrent difference that agrees well with the shot-noise limit (SNL), and curve b is the sum of two photocurrents. The electronic noise

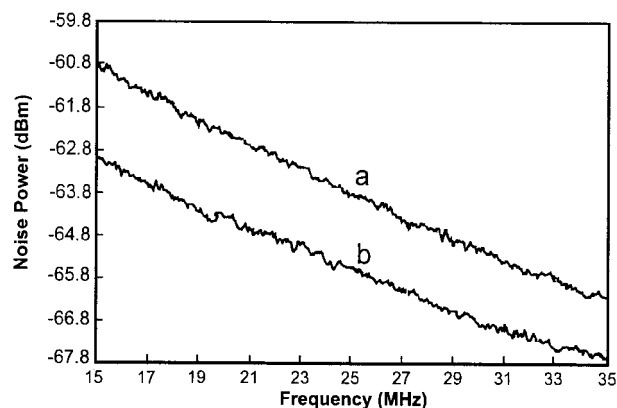

Fig. 2. Measured noise power spectra for the squeezed meter source. Curve a, shot-noise limit (SNL); curve b, noise power of the diode laser with a 9.06-mA dc detector current.

floor is checked to be a maximum of 13 dB. The squeezing of ~ 2.2 dB was obtained in the frequency range between 15 and 35 MHz. If the efficiency of the detection system (90%) is taken into account, the exact noise squeezing in the meter wave at the beam splitter (PBS2) should be ~ 2.5 dB.

In the experiment the conditional variance is characterized by the quantum correlation between the output signal and meter waves, which is just the optimum noise reduction of differential photocurrent $(i_2 - gi_3)^2$ between the amplified detectors PD2 and PD3 relative to the shot-noise level of the output signal.²² Curve (1) in Fig. 3 is the shot-noise power spectrum of the output signal wave that has been checked by the source of red-filtered white light, and it is also calibrated by the wideband infrared LED (Hitachi L2656) light, the central wavelength of which is 780 nm. Curve (2) is the lowest noise power spectrum of the different ac photocurrent between two detectors PD2 and PD3, the direct current (dc) of which is 8.6 mA. The electronic noise level of the amplifier in this condition is 18 dB below the SNL at the analysis frequency of 15 MHz and 12 dB at 30

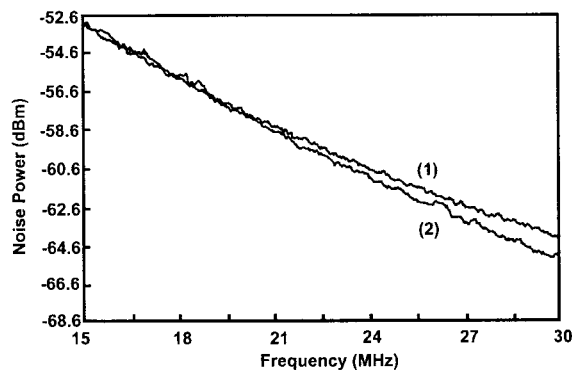

Fig. 3. Quantum correlation for the output signal and meter waves. Curve (1) is the SNL of the output signal wave calibrated by infrared white light with the 8.6-mA dc detector current; curve (2) is the difference noise power spectra of the output signal and meter waves.

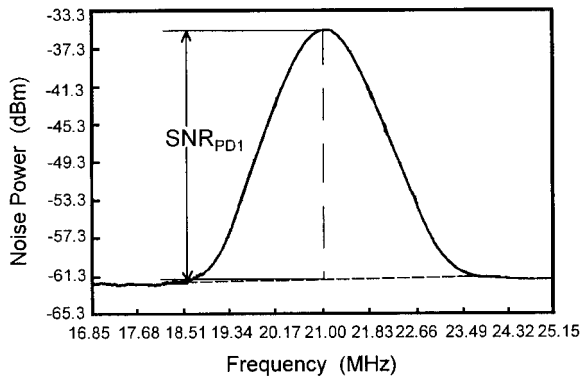

Fig. 4. Spectral density of the PD1 photocurrent fluctuation. The height of the peak gives the signal-to-noise ratio (SNR).

MHz. The resolution bandwidth of the spectrum analyzer is 300 kHz, and the video bandwidth is 1 kHz. In this case 1.0 dB of noise reduction is found and from that the conditional variance of 0.8 is obtained. As the result for the squeezing measurement, the conditional variance of 0.8 should be shown across the whole frequency range of the measurement. For the difficult measurements system, the decorrelation at the range of low frequencies is due to the presence of modal partition noise for LD; the other elements for decorrelation may be out of the in-phase between the input signal and meter waves, resulting from the servo loop system or the external noise injection during the measurement.²³

For characterization of the optical tap, the signal wave was modulated by an amplitude modulator at rf $\Omega = 21$ MHz. A beam splitter of reflectivity $R_m = 46\%$ in the signal beam extracted a part of the input signal for the measurement of the SNR of the input (SNR_s^{in}) that can be deduced from the directly measured SNR (SNR_{PD1}) by the detector PD1,

$$\text{SNR}_s^{\text{in}} = \text{SNR}_{\text{PD1}}(1 - R_m)/(R_m\eta_1), \quad (6)$$

where $\eta_1 = 90\%$ is the detection efficiency of PD1. Figure 4 shows the noise power spectra of the pho-

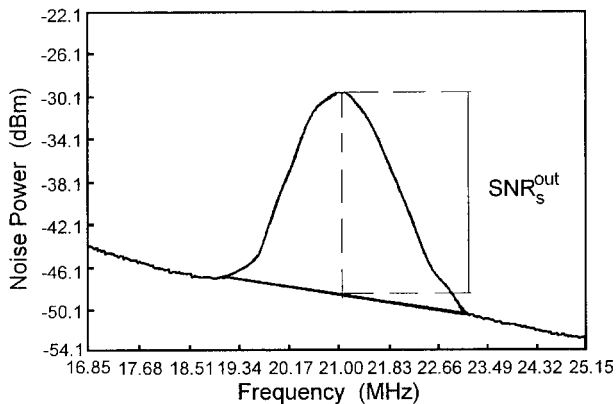

Fig. 5. Noise power spectra of the output signal wave. The SNR of the output signal wave is given by the peak at 21 MHz, which is transferred from the modulation of the input signal wave.

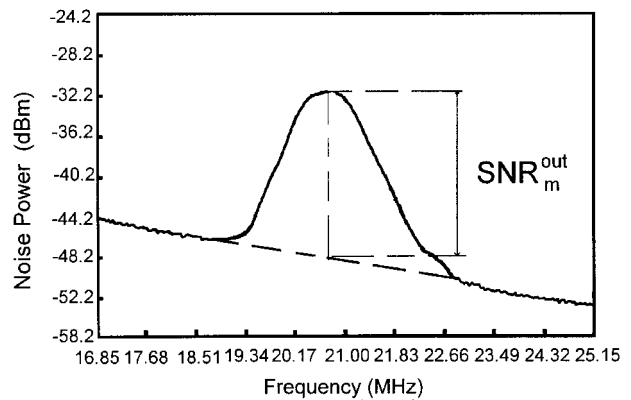

Fig. 6. Noise power spectra of the output meter wave. The 21-MHz modulation signal gives the SNR of output meter wave.

tocurrent detected by PD1; the SNR of the input signal $\text{SNR}_s^{\text{in}} = 33.9$ dB is obtained from the measured date of SNR_{PD1} and Eq. (6). Figures 5 and 6 are the SNR of the output signal and meter waves directly detected by the noise spectra of the photocurrents at PD2 and PD3; that is, $\text{SNR}_s^{\text{out}} = 19.3$ dB and $\text{SNR}_m^{\text{out}} = 17.0$ dB. The transfer coefficient $T = T_s + T_m = 1.07$ is estimated by the detected fraction of the SNR of the output signal and meter waves to that of the input wave, where T is slightly larger than the quantum limit of 1.

In conclusion, we demonstrated for the first time to our knowledge the quantum measurement that met the QND criteria of $V_{s/m} < 1$ and $T > 1$ with the amplitude-squeezed LD input meter wave of a beam splitter. In principle the perfect QND can be reached when the amplitude squeezing and detection efficiency are perfect, and the maximum measurements of $T = 1.12$ and $V_{s/m} = 0.75$ will be reached when the squeezing of the input meter wave is 2.5 dB and the detection efficiency of the system is 0.9. In practice the measured transfer coefficient $T = 1.07$, and the ability of quantum-state preparation $V_{s/m} = 0.8$ are obtained. Along with the improvement of LD squeezing and detection efficiency, the quality of measurement must be improved. We believe that with the compact and reliable all-solid-state system, the presented scheme might be useful for practical application.

This research was supported by the National Natural Science Foundation C 69837010, the Overseas Youth Scholar Collaboration Foundation (69928504), and the Shanxi Province Young Science Foundation (20001016).

References

1. V. B. Braginsky, Y. I. Vorontsov, and K. S. Thorne, "Quantum nondemolition measurements," *Science* **209**, 547–556 (1980).
2. M. D. Levenson, R. M. Shelby, M. Reid, and D. F. Wall, "Quantum nondemolition detection of optical quadrature amplitudes," *Phys. Rev. Lett.* **57**, 2473–2476 (1986).
3. A. La Porta, R. E. Slusger, and B. Yurke, "Back-action evading measurement of an optical field parametric down conversion," *Phys. Rev. Lett.* **12**, 28–31 (1989).

4. S. F. Pereira, Z. Y. Ou, and H. J. Kimble, "Back-action evading measurements for quantum nondemolition detection and quantum optical tapping," *Phys. Rev. Lett.* **72**, 214–217 (1994).
5. E. Goobar, A. Karlsson, and G. Bjork, "Experimental realization of a semiconductor photon number amplifier and a quantum optical tap," *Phys. Rev. Lett.* **71**, 2002–2005 (1993).
6. J. F. Roch, J. P. Poizat, and P. Grangier, "Sub-shot noise manipulation of light using semiconductor emitters and receivers," *Phys. Rev. Lett.* **71**, 2006–2009 (1993).
7. A. B. Matsko and S. P. Vyatchanin, "A ponderomotive scheme for QND measurement of quadrature component," *Appl. Phys. B* **64**, 167–171 (1997).
8. R. Bruckmeier, K. Schneider, S. Schiller, and J. Mlynek, "Quantum nondemolition measurements improved by a squeezed meter input," *Phys. Rev. Lett.* **78**, 1243–1246 (1997).
9. R. Bruckmeier, K. Schneider, H. Hansen, M. Schalke, S. Schiller, and J. Mlynek, "Continuous-wave quantum nondemolition measurements with vacuum and nonclassical meter input," *Appl. Phys. B* **64**, 203–212 (1997).
10. J. H. Shapiro, "Optical waveguide tap with infinitesimal insertion loss," *Opt. Lett.* **5**, 351–353 (1980).
11. M. J. Holland, M. J. Collett, D. F. Walls, and M. D. Levenson, "Nonideal quantum nondemolition measurements," *Phys. Rev. A* **42**, 2995–3005 (1990).
12. R. Bruckmeier, H. Hansen, S. Schiller, and J. Mlynek, "Realization of a paradigm for quantum measurements: the squeezed light beam splitter," *Phys. Rev. Lett.* **79**, 43–46 (1997).
13. H. Wang, Y. Zhang, Q. Pan, H. Su, A. Porzio, C. Xie, and K. Peng, "Experimental realization of a quantum measurement for intensity difference fluctuation using a beam splitter," *Phys. Rev. Lett.* **82**, 1414–1417 (1999).
14. D. C. Kilper, D. G. Steel, R. Craig, and D. R. Scifres, "Polarization-dependent noise in photon-number squeezed light generated by quantum-well lasers," *Opt. Lett.* **21**, 1283–1285 (1996).
15. H. Wang, M. J. Freeman, and D. G. Steel, "Squeezing light from injection-locked quantum well lasers," *Phys. Rev. Lett.* **71**, 3951–3954 (1993).
16. Y. Q. Li, P. Lynam, M. Xiao, and P. J. Edwards, "Sub-shot-noise laser Doppler anemometry with amplitude-squeezed light," *Phys. Rev. Lett.* **78**, 3105–3108 (1997).
17. D. C. Kilper, A. C. Schaefer, J. Erland, and D. G. Steel, "Coherent nonlinear optical spectroscopy using photon-number squeezed light," *Phys. Rev. A* **54**, R1785–R1788 (1996).
18. S. Kasapi, S. Lathi, and Y. Yamamoto, "Amplitude-squeezed, frequency-modulated, tunable, diode-laser-based source for sub-shot-noise FM spectroscopy," *Opt. Lett.* **22**, 478–480 (1997).
19. F. Marin, A. Bramati, V. Jost, and E. Giacobino, "Demonstration of high sensitivity spectroscopy with squeezed semiconductor lasers," *Opt. Commun.* **140**, 146–157 (1997).
20. J. A. Levenson, I. Abram, T. Rivera, P. Fayolle, J. C. Garreau, and P. Grangier, "Quantum optical cloning amplifier," *Phys. Rev. Lett.* **70**, 267–269 (1993).
21. J. Ph. Poizat and P. Grangier, "Experimental realization of a quantum optical tap," *Phys. Rev. Lett.* **70**, 271–274 (1993).
22. J. P. Poizat, J. F. Roch, and P. Grangier, "Characterization of quantum non-demolition measurements in optics," *Ann. Phys. Fr. (Paris)* **19**, 265–297 (1994).
23. Y. Q. Li, P. J. Edwards, P. Lynam, and W. N. Cheung, "Quantum-correlated light from transverse junction stripe laser diodes," *Int. J. Optoelectron.* **10**, 417–421 (1995).